



*The Processor People*

# PLATEPRO SERIES

PROCESSORS FOR THERMAL PLATE MATERIAL



## ***Large Developing Capacity for CTP***

- *Can also develop conventional plates*
- *No special power requirements, 13amp socket only (except for 1300)*
- *Quick release roller system*
- *Adjustable speed developer brushes*
- *Electronic plate counter*
- *Chiller unit incorporated as standard*

## ***Optional Extras***

- *Developer and Gum replenisher containers*
- *Recirculating wash water*
- *PlatePro Deluxe Mobile Stacker*

*Success in partnership with THE Processor People*

# Platepro+CTP AVAILABLE IN 3 WIDTH OPTIONS: 66cm 88cm 130cm

The **PlatePro+CTP** plate processors developer tank eliminates bow waves that ensures high quality and stable development and has a high linier speed for faster results.

A new gum wash system operates automatically for 5 minutes when the processor is put in night mode, or when the processor is not in use for long periods.

The automatic developer replenishment system accurately calculates the plate surface to ensure optimum activity and economises on chemistry.

A quick release system for removing and replacing the rollers within several seconds, without the need for any tools, makes cleaning and maintaining the rollers a very simple task.

The most convenient and positive roller pressure system has been designed to adjust and maintain the required pressure of the rubber rollers for all types of materials.

There is a power separating system feature. This automatically adjusts the power taken between the developer and dryer during the processing operation. Using this feature enables the 660 and 880 sizes of the **PlatePro+CTP** to use only a 13 Amp socket.

The **PlatePro+CTP** series plate processors have two rotating scrub rollers in the developer section. This makes the processor suitable for both positive and negative working. Also 2 drive rollers in the developer section ensure a consistent and smooth travel for the plate.

A brush in the wash section cleans the plate more efficiently. This feature ensures consistent plate processing quality.

A stainless steel filter housing - easy to clean cartridge for developer is a standard feature. This ensures that no foreign matter interferes with the surface of the plate as it is developed.

A water recycling system is continually circulating used water with recycled water, so that no water is wasted. A unique design in the water recycling system allows the user to change the recycled water easily. (Optional).

A chiller facility is incorporated into the developer bath to ensure a consistent temperature, giving a more reliable plate quality.

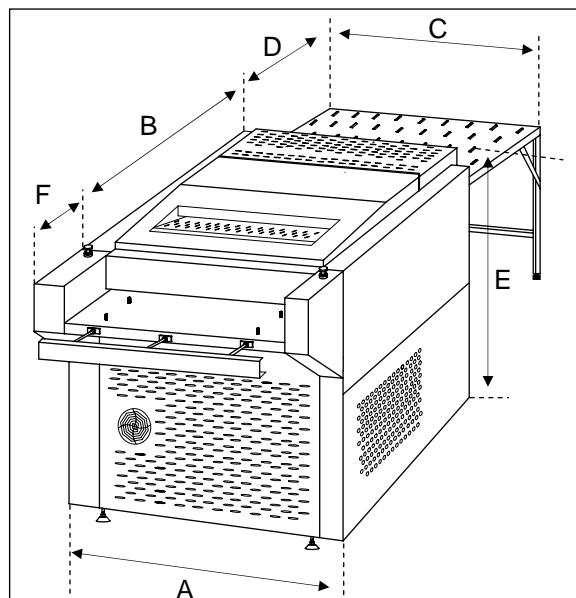

	660 CTP	880 CTP	1300 CTP
A	108.5 CM	130.5 CM	164CM
B	150CM	150 CM	160CM
C	71CM	93CM	135CM
D	90 CM	100 CM	140 CM
E	105 CM	105 CM	105 CM
F	10 cm Online / 35 cm Offline		

PLATE SIZE		
660	Width max 66cm	Length unlimited
	Width min 25cm	Length min 40cm
880	Width max 88cm	Length unlimited
	Width min 25cm	Length min 40cm
1300	Width max 130cm	Length unlimited
	Width min 25cm	Length min 40cm

**Plate Thickness** → 0.12 – 0.40mm

**Developer Speed Control** → 12-60 Seconds

Plate Processing Speed	
at 25 secs dev. time	660 = 192cm/min
	880 = 192cm/min
	1300 = 192cm/min

**Replenishing System**  
(Exhaustion) Scanner Automatic Replenishment (Anti Oxidation) Separate Day/Night Automatic Replenishment

Developer Capacity	
660 CTP	Bath 54.5 Ltr + Filter 2 Ltr
880 CTP	Bath 69.0 Ltr + Filter 2 Ltr
1300 CTP	Bath 97.8 Ltr + Filter 2 Ltr

**Gum Capacity** Direct From Container

**Dryer Temperature Control** 30°C – 60°C

<b>Water Outlet Connection</b>	Ø 22mm
<b>Water Inlet Connection</b>	3 / 4 " washing machine connection
<b>Power</b>	660 & 880 = single phase 13amp Supply
	1300 = single phase 20amp Supply
<b>Machine Weight</b>	660 CTP 325 kgs
	880 CTP 430 kgs
	1300 CTP 579 kgs
<b>Packing Weight</b>	660 CTP 470 kgs
	880 CTP 591 kgs
	1300 CTP 799 kgs
<b>Packing Size</b>	660 CTP 212 x 135 x 121
	880 CTP 212 x 145 x 121
	1300 CTP 212 x 190 x 121



**IGP UK LIMITED**  
The Offices above Unit 5  
The Maltings, Maltings Road  
Battlesbridge Essex  
SS11 7RH  
TEL: 01245 323555  
FAX: 01245 323762

Why not visit our website and view our large range of products.  
**WEBSITE:** [igp-ukltd.co.uk](http://igp-ukltd.co.uk)  
To contact our sales department you can email us direct.  
**E-Mail:** [sales@igp-ukltd.co.uk](mailto:sales@igp-ukltd.co.uk)



Certificate No. 6139