



The Processor People

PLATEPRO SERIES

PROCESSORS FOR PHOTOPOLYMER with Pre-heat and Pre-wash



Large Developing Capacity for CTP

- Available In 4 Width Options
- Pre-Wash and Pre-Heat
- Quick release roller system
- Adjustable speed developer brushes
- Electronic plate counter
- Chiller unit incorporated as standard

Optional Extras

- Developer and Gum replenisher containers
- Recirculating wash water
- PlatePro Deluxe Mobile Stacker

Success in partnership with THE Processor People

Photopolymer CTP is available in 4 width options: 66cm, 88cm, 130cm & 160cm

- The **Photopolymer+CTP** plate processor has an integrated Pre-heat and Pre-wash system
- The **Photopolymer+CTP** plate processors developer tank eliminates bow waves that ensures high quality and stable development and has a high liner speed for faster results.
- A new gum wash system operates automatically for 5 minutes when the processor is put in night mode, or when the processor is not in use for long periods.
- The automatic developer replenishment system accurately calculates the plate surface to ensure optimum activity and economises on chemistry.
- A quick release system for removing and replacing the rollers within several seconds, without the need for any tools, makes cleaning and maintaining the rollers a very simple task.
- The most convenient and positive roller pressure system has been designed to adjust and maintain the required pressure of the rubber rollers for all types of materials.
- A brush in the wash section cleans the plate more efficiently. This feature ensures consistent plate processing quality.
- A stainless steel filter housing - easy to clean cartridge for developer is a standard feature. This ensures that no foreign matter interferes with the surface of the plate as it is developed.
- A chiller facility is incorporated into the developer bath to ensure a consistent temperature, giving a more reliable plate quality.



PLATE SIZE		
660	Width max 66cm	Length unlimited
	Width min 25cm	Length min 38cm
880	Width max 88cm	Length unlimited
	Width min 25cm	Length min 38cm
Plate Thickness		0.12 – 0.40mm
Developer Speed Control		15-60 Seconds
Plate Processing Speed		
15 secs		86cm/min
25 secs		50cm/min
Replenishing System		
(Exhaustion) Scanner Automatic Replenishment (Anti Oxidation) Separate Day/Night Automatic Replenishment		
Developer Capacity	660 CTP Bath 17 Litres Total 880 CTP Bath 23 Litres Total	
Gum Capacity	Direct From Container	
Dryer Temperature Control		30°C – 60°C
Water Outlet Connection		Ø 38mm
Water Inlet Connection		3 / 4 " X 3
Power	20 amp 3 Phase	

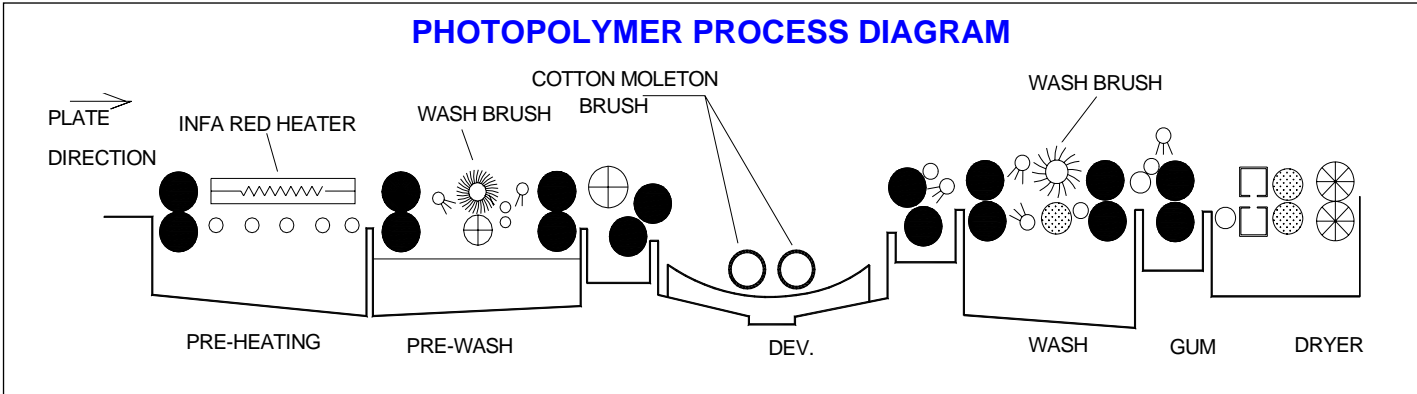
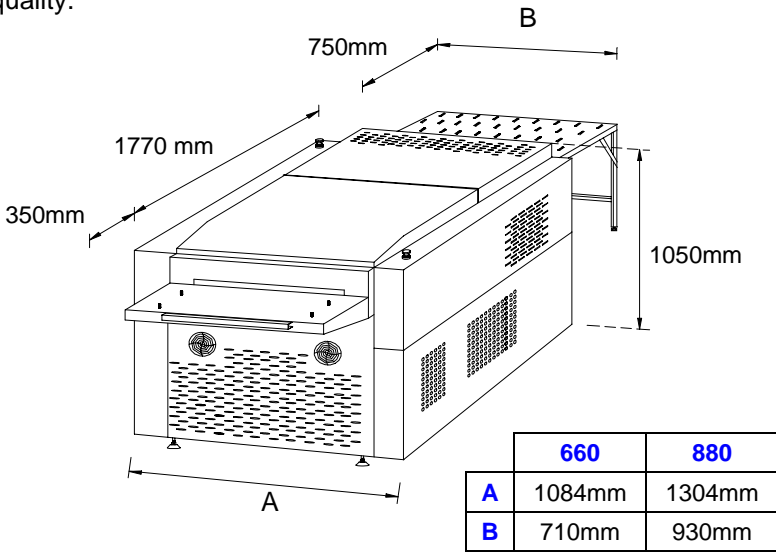

IGP UK LIMITED
 The Offices above Unit 5
 The Maltings, Maltings Road
 Battlesbridge Essex
 SS11 7RH
 TEL: 01245 323555
 FAX: 01245 323762

Why not visit our website and view our large range of products.
WEBSITE: igp-ukltd.co.uk
 To contact our sales department you can email us direct.
E-Mail: sales@igp-ukltd.co.uk

